



# Freedom to Roam

World's First Battery-Powered Kegerator



# FREEDOM<sup>TM</sup> KEGENERATOR

Patented Technology Licensed By

**HYBRIDKEGENERATOR, INC.**

PATENT NO. 7,735,334 B2



MMF-B



# Cold, Cordless & Portable!



Patented Technology Licensed By  
**HYBRIDKEGERATOR, INC.**

PATENT NO. 7,735,334 B2

## Introducing the World's First Kegerator with a Revolutionary Hybrid Power Source!

Conventional kegerators require AC power at all times, with the Micro Matic Freedom™ Kegerator you have the option of using AC power or battery power to keep your keg cold.

- The Freedom™ Kegerator **Delivers on-demand draft beer dispensing** to high traffic areas when and where you want it!
- **No Power, No Worry...** Plug-in at night and Pour during the day, the Freedom™ Kegerator keeps the keg cold on battery power for up to 24 hours.
- **Patented Power Unit** delivers worry-free operations, simplifies operational planning, captures incremental sales and more.
- **Eco-Friendly!** Battery power eliminates the need for specialized dispensing equipment that requires ice and water for cooling cold plates and coils – no ice, no waste water, no mess!

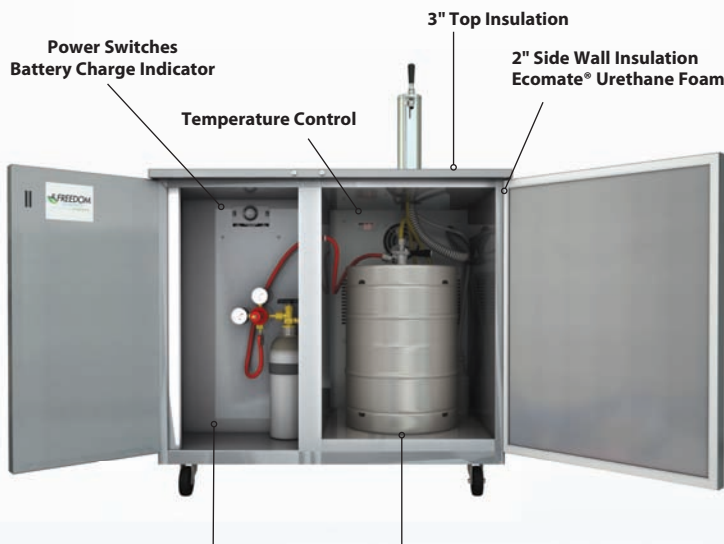
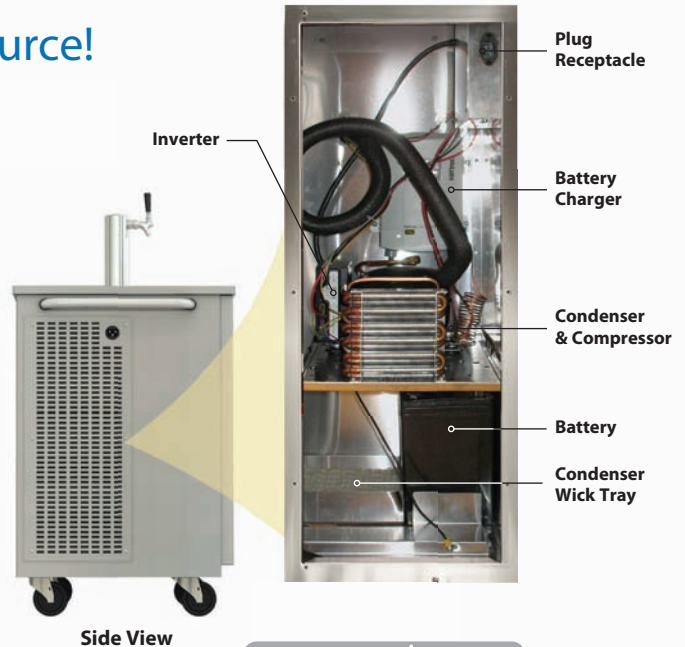

Separate Gas Cylinder Compartment\*  
(Shown with Tapping Kit) Holds All Keg Sizes\*



Back View

\* Keg & Tapping Kit NOT INCLUDED.



# Specifications

Micro Matic reserves the right to change specifications without notice. **AUTOQUOTES**

Part No.	Exterior Finish	Doors	Shipping Weight	Box Dimensions
☐ <b>MMF-B</b>	Stainless Steel	2	113 kg	1194mm L x 838mm W x 1143mm H
			250 lbs	47"L x 33"W x 45"H

## Operating Performance

<b>Capacity of 1/2 Kegs</b>	1	<b>Running Amps</b>	8 amps DC 2.8 amps AC with battery charger on 1.4 amps AC with battery charger off
<b>Cubic Feet (liters)</b>	6.9	<b>Battery</b>	Deep Cycle -12 Volt (Sealed)
<b>Number of Draft Towers</b>	1	<b>Voltage</b>	12 Volt DC/120 Volts AC
<b>Number of Faucets</b>	1	<b>Plug Type</b>	NEMA-5-15R w/C-13 connector
<b>Beer Tower Approval</b>	NSF 7.0 and NSF 18	<b>Cord Length</b>	8'
<b>AC/DC Compressor</b>	BD50	<b>Approval</b>	ETL Listed
<b>Refrigerant</b>	R-134A		
<b>Charge oz (Grs)</b>	6		

<b>Exterior</b>	18 gauge stainless steel
<b>Interior</b>	22 gauge galvanized
<b>Ventilation</b>	Side ventilated
<b>Plumbing</b>	Automatic condensate evaporator, no drain connection required
<b>Insulation</b>	Ecomate® Foamed-in-place high density CFC-free polyurethane; 3" top with 2" doors
<b>Castors</b>	4 (installed)

## Added Value Features



- Digital temperature control.
- Battery charge indicator.
- Continuous air-cooling of draft tower for a cold first pour.
- Flush mount stainless steel drip tray with drain bottle.
- Convenient easy access storage space for gas cylinder and serving cups.
- Locking doors.
- Recessed door handles.
- Integral stainless steel hand push bar for easy mobility.
- 30% higher R-value insulation rating than standard Kegenerators.

## Dimensions

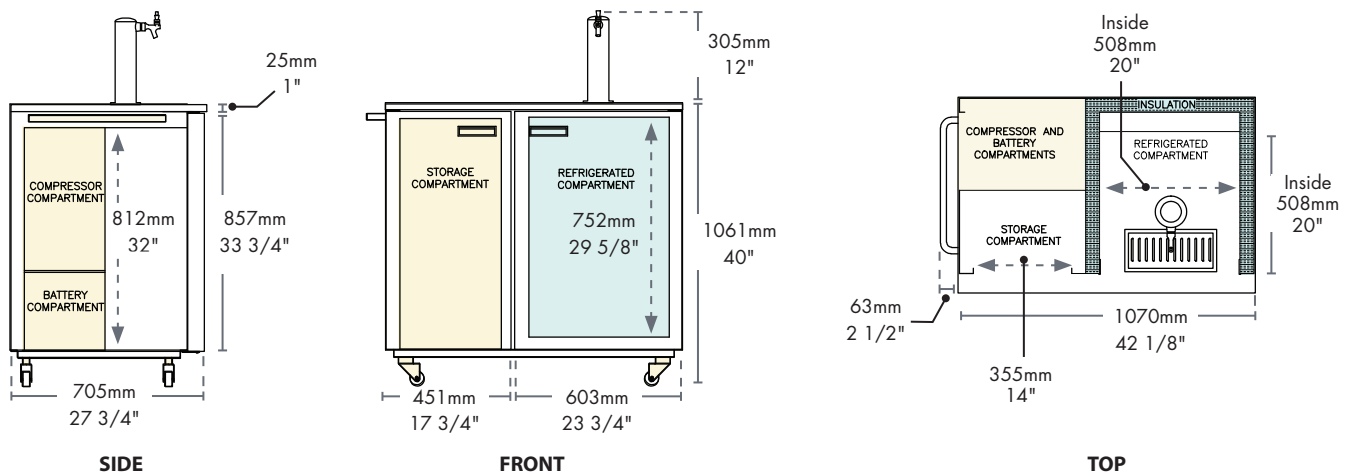

00997-D0711 Copyright ©2011 Micro Matic USA, Inc. All Rights Reserved.



[www.micromatic.com](http://www.micromatic.com)

Toll Free: 1-(866) 327-4159

West	Central	Southeast	Northeast
19791 Bahama Street Northridge, CA 91324 Tel. (818) 701-9765 Fax. (818) 701-9844	10726 North Second Street Machesney Park, IL 61115 Tel. (815) 968-7557 Fax. (815) 968-0363	2364 Simon Court Brooksville, FL 34604 Tel. (352) 799-6331 Fax. (352) 796-2429	4601 Saucon Creek Road Center Valley, PA 18034 Tel. (610) 625-4464 Fax. (610) 625-4466